

AMPROBE®

HARD AT WORK SINCE 1948.

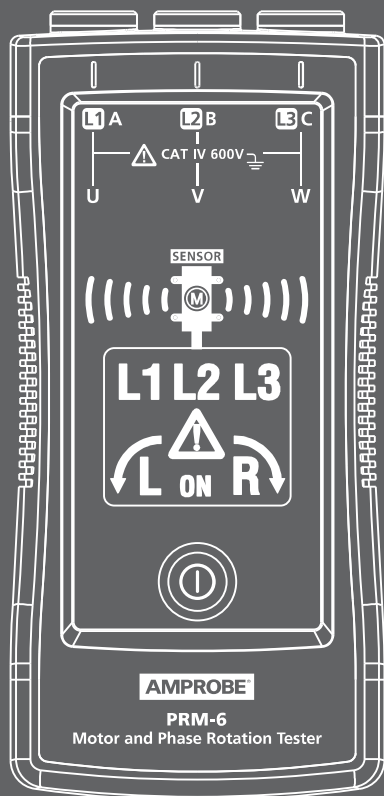

PRM-6

Motor and Phase Rotation Tester

User Manual

- Manual de usuario
- Manuel de l'utilisateur
- Manual dos Usuários

PRM-6

Motor and Phase Rotation Tester

Users Manual

English

4/2015, Rev A
©2015 Amprobe Test Tools.
All rights reserved. Printed in China

Limited Warranty and Limitation of Liability

Your Amprobe product will be free from defects in material and workmanship for one year from the date of purchase unless local laws require otherwise. This warranty does not cover fuses, disposable batteries or damage from accident, neglect, misuse, alteration, contamination, or abnormal conditions of operation or handling. Resellers are not authorized to extend any other warranty on the behalf of Amprobe. To obtain service during the warranty period, return the product with proof of purchase to an authorized Amprobe Service Center or to an Amprobe dealer or distributor. See Repair Section for details. THIS WARRANTY IS YOUR ONLY REMEDY. ALL OTHER WARRANTIES - WHETHER EXPRESS, IMPLIED OR STATUTORY - INCLUDING IMPLIED WARRANTIES OF FITNESS FOR A PARTICULAR PURPOSE OR MERCHANTABILITY, ARE HEREBY DISCLAIMED. MANUFACTURER SHALL NOT BE LIABLE FOR ANY SPECIAL, INDIRECT, INCIDENTAL OR CONSEQUENTIAL DAMAGES OR LOSSES, ARISING FROM ANY CAUSE OR THEORY. Since some states or countries do not allow the exclusion or limitation of an implied warranty or of incidental or consequential damages, this limitation of liability may not apply to you.

Repair

All Amprobe returned for warranty or non-warranty repair or for calibration should be accompanied by the following: your name, company's name, address, telephone number, and proof of purchase. Additionally, please include a brief description of the problem or the service requested and include the test leads with the meter. Non-warranty repair or replacement charges should be remitted in the form of a check, a money order, credit card with expiration date, or a purchase order made payable to Amprobe.

In-warranty Repairs and Replacement – All Countries

Please read the warranty statement and check your battery before requesting repair. During the warranty period, any defective test tool can be returned to your Amprobe distributor for an exchange for the same or like product. Please check the "Where to Buy" section on www.Amprobe.com for a list of distributors near you. Additionally, in the United States and Canada, in-warranty repair and replacement units can also be sent to an Amprobe Service Center (see address below).

Non-warranty Repairs and Replacement – United States and Canada

Non-warranty repairs in the United States and Canada should be sent to an Amprobe Service Center. Call Amprobe or inquire at your point of purchase for current repair and replacement rates.

USA:	Canada:
Amprobe	Amprobe
Everett, WA 98203	Mississauga, ON L4Z 1X9
Tel: 877-AMPROBE (267-7623)	Tel: 905-890-7600

Non-warranty Repairs and Replacement – Europe

European non-warranty units can be replaced by your Amprobe distributor for a nominal charge. Please check the "Where to Buy" section on www.Beha-Amprobe.com for a list of distributors near you.

Amprobe Europe*
Beha-Amprobe
In den Engematten 14
79286 Glottertal, Germany
Tel.: +49 (0) 7684 8009 - 0
www.Beha-Amprobe.com

*(Correspondence only – no repair or replacement available from this address. European customers please contact your distributor.)

PRM-6 Motor and Phase Rotation Tester

CONTENTS

SYMBOL.....	3
SAFETY INFORMATION	3
UNPACKING AND INSPECTION	5
USING PHASE SEQUENCE & MOTOR ROTARY TESTER.....	5
Determine the Rotary Field Direction	5
Non-Contact Rotary Field Indication.....	6
Determine the Motor Connection.....	7
Backlight	8
SPECIFICATIONS.....	8
MAINTENANCE.....	9
Cleaning	9
Replacing and Disposing of the Battery.....	10

1



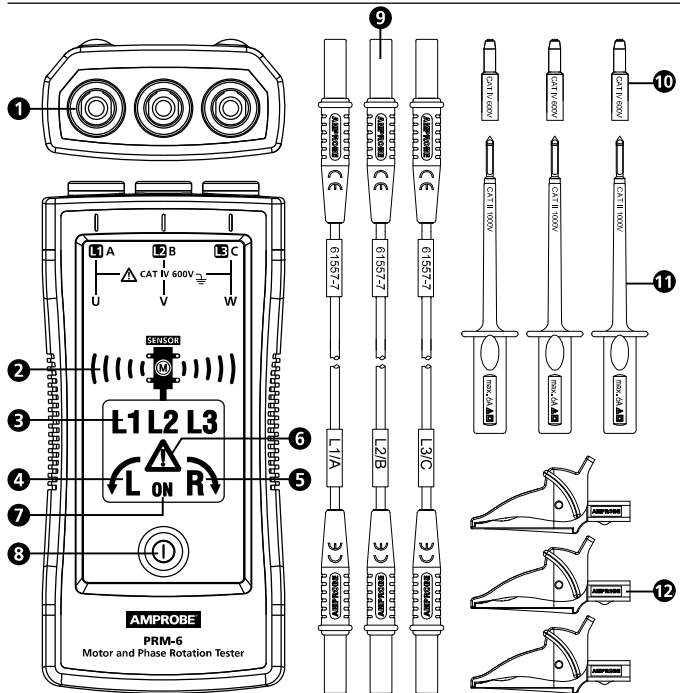





PRM-6 Motor and Phase Rotation Tester



- | | |
|---|--|
| 1 Input terminals for L1 (A), L2 (B), L3 (C) | 7 ON symbol for Non-Contact Rotary Field Indication and Determine the Motor Connection |
| 2 Non-contact motor orientation symbol and sensor indicator | 8 ON button / Backlight |
| 3 Symbol for L1, L2, L3 indicators | 9 Test leads (black, red, yellow) |
| 4 Symbol for counter-clockwise rotation | 10 Probe tip cap (black, red, yellow) |
| 5 Symbol for clockwise rotation | 11 Test probe (black, red, yellow) |
| 6 "Warning symbol" for false input voltage | 12 Alligator clips (black, red, yellow) |

2

SYMBOLS

	Caution! Risk of electric shock.
	Caution! Refer to the explanation in this manual.
	The equipment is protected by double insulation or reinforced insulation
	Earth (Ground)
CAT IV	Measurement category IV (CAT IV) is for measurement performed at the source of the low-voltage installation. Examples are electricity meters and measurement on primary overcurrent protection device and ripple control units.
	Orientation symbol for non-contact motor rotary field indication.
CE	Complies with European Directives.
	Conforms to relevant Australian standards
	Canadian Standards Association (NRTL/C).
	Do not dispose of this product as unsorted municipal waste. Contact a qualified recycler.

SAFETY INFORMATION

The meter complies with:

IEC/EN 61557-1/-7

IEC/EN 61010-1 3rd Edition, UL61010-1 3rd Ed. and CAN/CSA C22.2 No. 61010-1-12 to CAT IV 600 V, pollution degree 2

IEC/EN 61010-2-030

IEC/EN 61010-2-31 for test leads

EMC IEC/EN 61326-1

CENELEC Directives

The instruments conform to CENELEC low-voltage directive 2006/95/EC and electromagnetic compatibility directive 2004/108/EC.

3

Warning

To prevent possible electrical shock, fire, or personal injury:

- Carefully read all instructions. Read safety information before using or servicing the tester.
- Comply with local and national safety codes. Use personal protective equipment (approved rubber gloves, face protection, and flame resistant clothes) to prevent shock and arc blast injury where hazardous live conductors are exposed.
- Use the product only as specified, or the protection supplied by the product can be compromised.
- Do not work alone.
- Consider mechanical risks and risks of rotating mechanical parts. Comply with local and national safety codes.
- Do not use the tester or test leads if they appear damaged. Examine the tester and test leads for damaged insulation or exposed metal. Check test lead continuity. Replace damaged test leads before using the tester.
- Do not touch voltages >30 V AC RMS, 42 V AC peak, or 60 V DC. These voltages pose electrical shock hazards. Keep fingers behind the finger guards on the probes and alligator clips.
- To avoid false readings, which could lead to possible electric shock or personal injury, check the battery and verify operation beforehand on a known source.
- Do not exceed the Measurement Category (CAT) rating of the lowest rated individual component of a product, probe, or accessory.
- If the tester is used in a manner not specified in the users manual, the protection provided by the equipment may be impaired.
- Measurements can be adversely affected by impedances of additional operating circuits connected in parallel or by transient currents.
- Do not use the PRM-6 with any of the parts removed.
- Disconnect the test leads from energized circuits and from the tester before opening the battery cover.
- Do not use the product around explosive gas, vapor, or in damp or wet environments.
- Have the tester serviced only by qualified service personnel.
- Only use the test lead sets provided with the tester. Alternative test leads may not fulfill the requirements of EN 61557-7.

4

UNPACKING AND INSPECTION

Your shipping carton should include:

- 1 PRM-6 Motor and Phase Rotation Tester
- 3 Test leads (black, red, yellow)
- 3 Test probes (black, red, yellow)
- 3 Alligator clips (black, red, yellow)
- 2 1.5V AAA battery (installed)
- 1 Users manual
- 1 Carrying case

If any of the items are damaged or missing, return the complete package to the place of purchase for an exchange.

USING MOTOR AND PHASE ROTATION TESTER

Determine the Rotary Field Direction

To determine the rotary field direction:

1. Connect one end of test leads to the tester's corresponding terminals L1, L2, and L3.
2. Connect the alligator clips or the test probes to the other end of the test leads.
3. Connect the alligator clips/test probes to the three mains phases.
4. L1, L2 and L3 indicators shows voltage is present.
5. The clockwise or counter-clockwise rotary indicator shows the type of rotary field direction present.
6. If the "Warning Symbol" illuminates, either one or two of the inputs are connected to the neutral conductor or the voltage difference between the phases exceed 30% phase to phase or 65% between phase to neutral.

Note:

- The PRM-6 is powered by the motor or system being tested.
- In environment with poor light condition you can switch on the Backlight while pressing and hold button "ON" to improve visibility.

⚠️ ⚠️ Warning

The rotary indicator L1, L2 and L3 lights even if the neutral conductor, N, is connected instead of L1, L2, or L3. Refer to Figure 1 for more information about what appears on the back of the PRM-6.

5

DISPLAY	↻L	R↻	L1 A	L2 B	L3 C	⚠️
R↻ CORRECT	○	●	●	●	●	○
↻L FALSE	●	○	●	●	●	○
L1 MISSING	○	○	○	●	●	●
L2 MISSING	○	○	●	○	●	●
L3 MISSING	○	○	●	●	○	●
ONE INPUT CONNECTED TO N OR PE	○	○	●	●	●	●

○ OFF ● ON

Figure 1: Phase indication table
(also printed on the back of the PRM-6)

Non-Contact Rotary Field Indication

For non-contact rotary field indication:

1. Disconnect all test leads from the PRM-6 for safety reason.
2. Position the PRM-6 on the motor so it is parallel to the length of the motor shaft. The sensor of the tester should be in the center of the motor windings. The tester should be as close as possible to the motor. See Figure 2.
3. Press and hold the ON button. The LC display shows "ON," indicating the PRM-6 is ready for testing.
4. Either the clockwise or counter-clockwise rotary indicator will illuminate, showing the type of rotary field direction present.

If the LC display don't show the "ON" symbol, while pressing the ON button, the battery does not have a charge and needs to be replaced.

⚠️ The Indicator will not operate with motor controlled by frequency converters. The bottom of the PRM-6 should be oriented towards the drive shaft. See the Orientation Symbol on the PRM-6.

If the motor was disconnected from electricity for a long time (typically one year), the residual field / magnetization may be too weak for the tester to measure the rotation.

6

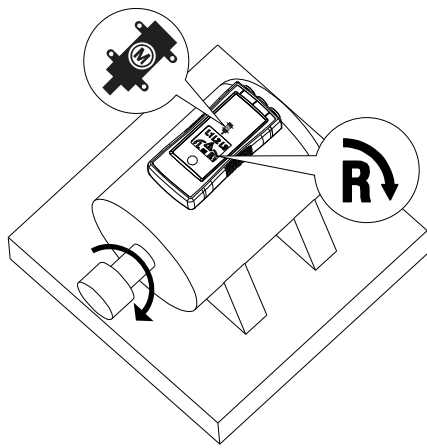

Figure 2: Motor Rotation

Determine the Motor Connection

1. Connect one end of test leads to the tester's corresponding terminals L1, L2, and L3.
2. Connect the alligator clips or the test probes to the other end of the test leads.
3. Connect the alligator clips or test probes to the motor connections, L1 to U, L2 to V, L3 to W.
4. Press the ON button. The LC display shows "ON," indicating the PRM-6 is ready for testing.
5. Turn the motor shaft towards the right.
6. Either the clockwise or counter-clockwise rotary indicator will illuminate, showing the rotary field direction.

If the LC display don't show the "ON" symbol, while pressing the ON button, the battery does not have a charge and needs to be replaced.

Note: If you get a another indication of the rotary field direction as expected then swap two connection from step 3 and repeat testing. Use the new order of U (L1), V (L2) and W (L3) for further purpose

Backlight

The backlight is turned on while pressing and hold button "ON" and it is powered by the battery.

If the backlight don't illuminate the battery does not have a charge and needs to be replaced.

SPECIFICATIONS

3 phase indication	Via LCD
Indication of phase rotation	Via LCD
Indication of motor rotation direction Non-contact rotary field indication	Via LCD
Determine the motor connection	Via LCD
LC display backlight	Yes
Determine Rotary Field Direction	
Frequency range (fn) / Voltage range (Ume)	16...60 Hz / 40...700V AC phase to phase >60...400 Hz / 50...700V AC phase to phase
Indicaton for false input voltage	difference of > ±30% between the phase to phase voltages (> ± 65% between phase to neutral voltages)
Nominal test current (In in per phase)	≤ 3.5 mA
Non-Contact Rotary Field Indication	
Frequency range (fn)	16 to 400 Hz
Determine the Motor Connection	
Voltage range (Ume)	≥ 1 V AC phase to phase
Frequency range (fn)	2 to 400 Hz
General Specifications	
Operating time	Continuous
Operating temperature	0°C to 40°C (32°F to 104°F)

Operating altitude	Up to 2000 m
Humidity (Without condensation)	≤ 80% RH
Storage conditions	0°C to 40°C (32°F to 104°F), ≤ 80% RH
Power supply	2 x 1.5 V AAA alkaline battery
Battery life	Minimum 2 years for average use
Dust/water resistance	IP 40
Pollution degree	2
Dimensions (H x W x D)	137 x 65 x 33 mm (5.43 x 2.56 x 1.3 in)
Weight	170 g (0.38 lb) (battery installed)
Product Standard	EN 61557 -1/-7
Electrical safety	EN 61010-1, EN 61557-7
Overvoltage category	CAT IV 600 V
EMC	Conforms to EN 61326-1
Agency approvals	

MAINTENANCE

Caution

To prevent damage to the PRM-6:

- Do not attempt to repair or service the PRM-6 unless qualified to do so.
- Make sure that the relevant calibration, performance test, and service information is being used.
- Do not use abrasives or solvents. Abrasives or solvents will damage the PRM-6 case.

Cleaning

The only maintenance the PRM-6 requires is inspection and cleaning. Periodically wipe the case with a mild solution of detergent and water. Apply sparingly with a soft cloth and allow to dry completely before using. Do not use aromatic hydrocarbons, gasoline or chlorinated solvents for cleaning.

9

Replacing and Disposing of the Battery

Warning

- To avoid electric shock, disconnect the test leads from the source before opening the PRM-6 for battery replacement.
- To avoid false readings, which could lead to possible electric shock or personal injury, replace the battery as soon as the battery is low or dead.

 **Note:** The PRM-6 contains alkaline battery. Do not dispose of the battery with other solid waste.

Used batteries should be disposed of by a qualified recycler or hazardous materials handler. Contact your authorized Amprobe Service center for recycling information.

The PRM-6 uses two 1.5 V AAA batteries (supplied). To replace the batteries, follow these steps and refer to Figure 3:

1. Disconnect test leads from any power source.
2. Place the PRM-6 face down on a nonabrasive surface and loosen the battery-door lock with a flat screwdriver.
3. Lift the battery cover away from the PRM-6.
4. Replace the batteries as shown in Figure 3. Observe the battery polarity shown in the battery compartment.
5. Replace the battery cover to the lock position.

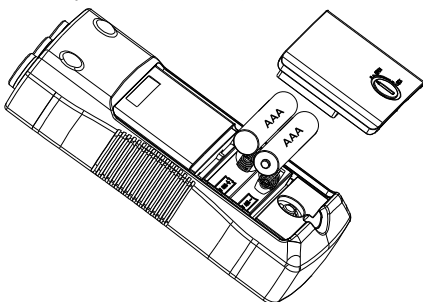

Figure 3: Replacing batteries